

本产品目录中所登录的产品，均按其使用目的，依照相关法规、规格所规定的功能及性能进行设计。用户在使用过程中，如果使之组装于机器设备中，或其他预料不到的情况下使用，而造成产品性能、功能的下降，或因不可预料的使用而引发的事故，本公司将不承担任何责任，如需特殊用途下使用时，请事先与彬野公司技术部门联系确认。

The products entered in this catalog products are all designed according to their application purposes, in compliance with functions and performances stipulated in related legal regulations and specifications. Our company shall undertake no responsibility at all for any deterioration of product performances of functions due to user assembly of them in machines and equipments, or application of them under other unexpected situations during use, or for any accidents arising from unexpected use. Please contact technical department of BNYEL company for confirmation in advance when application for special purposes is required.

由于公司坚持在产品开发中不断改进的原则，因此产品的规格可能有所变更，恕不另行通知。

For modification of product specification subjects to continuous betterment in development of BNYEL products, no notice will be given separately.

BNYEL



HHBB Electric Chain Hoist 环链电动葫芦



微信公众平台

彬野起重(上海)有限公司
BNYEL CRANES (SHANGHAI) CO.,LTD

地址：上海市嘉定区张店路161号
电话：+86-021-6155 9520 邮编：201816
传真：+86-021-5995 1268
邮箱：sales@bnyel.com
网站：www.bnyel.com

24小时
服务热线 4008 292 822



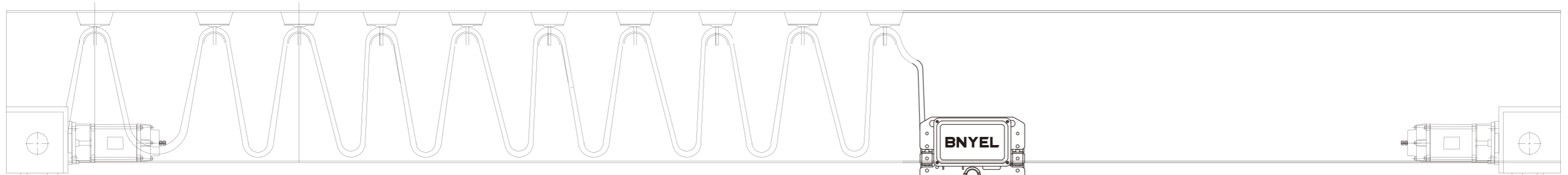

公司简介

彬野起重(上海)有限公司是全球领先的起重机及物料搬运产品的专业制造和服务供应商，致力于起重机及物料搬运技术的发展和研究，采用新理念，开发新产品，不断追求工业进步。公司凭借丰富的经验、专业的设计，为客户提供自重轻、净空低、安全可靠、性能优良和运行高效的满足各种工况的起重机产品，使客户能够减少厂房投资，提高生产效率，减少日常维护，节省运营能源消耗，取得良好的投资回报。

Company Profile

BNYEL Cranes (Shanghai) Co., LTD. is a global leader in the crane and material handling products manufacturing and service providers, committed to the development of crane and material handling technology and research, to adopt new ideas, new product development, the pursuit to industrial progress. Companies with rich experience, professional design, to provide customers with light weight, low headroom, safe and reliable, good performance and running efficiently to meet all kinds of working condition of crane products, satisfy customers of reducing facility investment, improving the production efficiency, reducing the daily maintenance, save operation energy consumption, obtaining good return on investment.

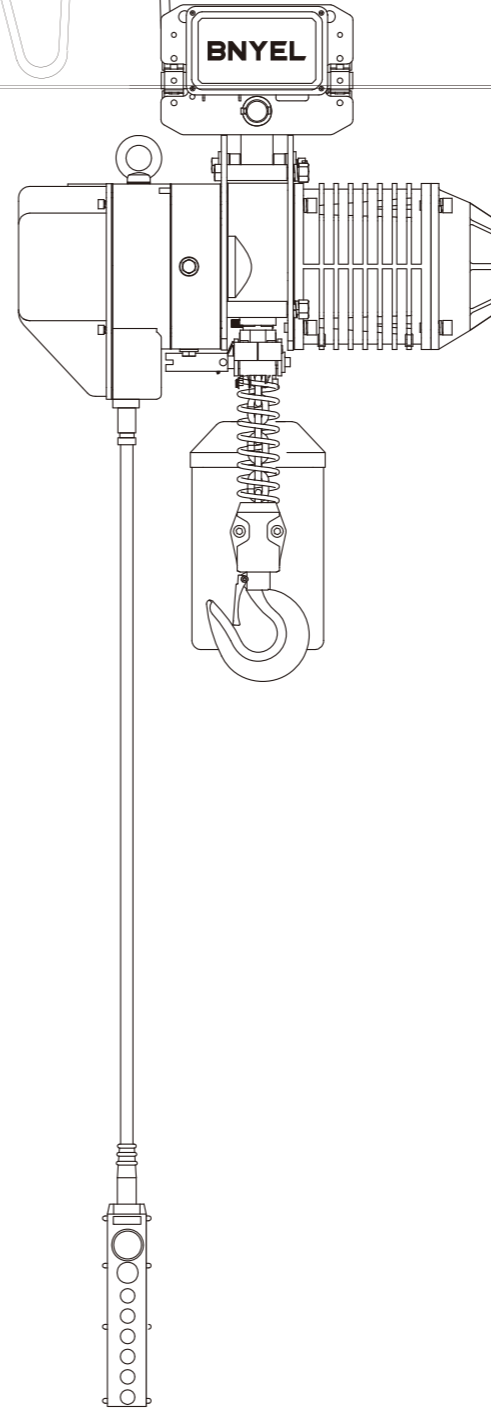

目录 Contents

01	产品编码，吊钩及链条规格 Product Code, Hook & Chain Specifications
02	产品结构图 Product Structure
03	500kg - 5t 挂钩式 500kg - 5t hook Suspension type
05	500kg - 5t 电动小车式 500kg - 5t Motorized trolley type
07	500kg - 5t 手动跑车式 500kg - 5t Plain trolley type
08	7.5t 电动小车式 7.5t Motorized trolley type
09	10t 挂钩/电动小车式 10t hook Suspension type & Motorized trolley type
10	10 15t- 25t 单速/双速电动小车式 15t- 25t Single Speed & Dual Speed Motorized trolley type
11	500kg - 10t 低净空式 500kg - 10t ultra Low headroom type
13	1000kg - 5000kg ER 系列电动环链葫芦 1000kg - 5000kg ER Serious Electric chain hoist
15	1000kg 舞台吊 1000kg Stagemaker Electric Chain Hoist
16	125kg-1000kg 欧式环联电动葫芦 125kg-1000kg Euro Standard Small Capacity Type
17	1000kg - 10000kg 防爆款式 1000kg - 10000kg Explosion-proof Exelectric Chain Hoist
19	电动/手动跑车 Motorized / Plain Trolley
20	葫芦工业等级 Hoist Classifications

产品代码 Products Code

HHBB 01 - 01 S S

Products Series 产品系列

Capacity 额定载荷

Chain Falls 链条回数

Lifting Speed 速度形式

Code 代码

Load 额定载荷(t)

Falls 链条回数

S 单速 Single Speed

D 双速 Dual Speed

S hook Suspension 挂钩式

P Plain trolley 手动小车式

M Motorized trolley 电动小车式

L ultra Low headroom 低净空式

Code	Load	Code	Falls
代码	额定载荷(t)	代码	链条回数
0.5	0.5	01	1
01	1	02	2
1.5	1.5	03	3
02	2	04	4
2.5	2.5	06	6
03	3	08	8
05	5	10	10
7.5	7.5	12	12
10	10		
15	15		
20	20		
25	25		



Type 机型	Load 负重(t)	T	B	A	B	C	D	E	G
HHBB	0.3, 0.5	T	B	27	18	25	17	35	28
	1	T	B	34	24	30	24	42	32
	2	T	B	46	29	39	30	49	40
	3	T	B	56	35	49	34	59	48
	5	T	B	67	43	57	44	60	48
	7.5	T	B	82	55	80	48	85	80
	10	T	B	82	55	80	48	85	80
	15	T	B	110	78	120	80	120	96
	20, 25	T	B	142	95	155	98	150	115
	30	T	B	160	130	150	130	140	95
35	T	B	195	150	160	150	160	110	

T-top hook/B-load hook T-上吊钩/B-下吊钩

Applicable Type 使用机型	Diameter 直径(mm)D	Inside Length 节距(mm)P	Inside Width 内宽(mm)A	Outside Width 外宽(mm)B	Work Load 工作负荷(kg)	Guaranteed Load 保证负荷(kN)	Break Load 最大破断负荷(kN)
HHBB 05-01	6.3	19	7.9	22	1120	27	47
HHBB 01-01	7.1	21	8.9	25	1600	37	61.6
HHBB 02-02	7.1	21	8.9	25	1600	37	61.6
HHBB 03-03	7.1	21	8.9	25	1600	37	61.6
HHBB 1.5-01	10.0	30	12.5	35	3200	76	125
HHBB 02-01	10.0	30	12.5	35	3200	76	125
HHBB 03-02	10.0	30	12.5	35	3200	76	125
HHBB 25-01	11.2	34	14	37.5	3800	92	154
HHBB 03-01	11.2	34	14	37.5	3800	92	154
HHBB 05-02	11.2	34	14	37.5	3800	92	154
HHBB 7.5-03	11.2	34	14	37.5	3800	92	154
HHBB 10-04	11.2	34	14	37.5	3800	92	154
HHBB 15-06	11.2	34	14	37.5	3800	92	154
HHBB 20-08	11.2	34	14	37.5	3800	92	154
HHBB 25-10	11.2	34	14	37.5	3800	92	154

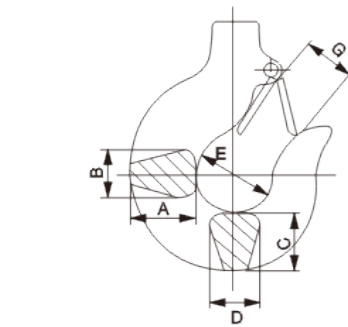

Hook 吊钩

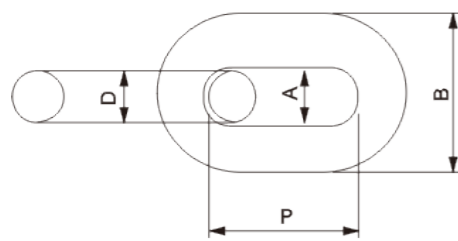

Chain 链条

Shell: It is made of light aluminum alloy shell, light but hard. The cooling fin is especially designed to ensure quick heat dissipation with the rate up to 40% and continuous service.

The integral enclosed structure is applicable to places like chemical plant and electroplate factory.

外壳: 铝合金外壳, 坚实而质轻。有特殊散热片, 散热快, 可连续使用, 效率达40%。整体密闭式结构, 可使用在化工厂、电镀厂等地方。

Side magnetic braking device: The magnetic orce generator is the latest design which is featured for generating magnetic force. It allows instant brake as soon as the electric power is cut off. Thus the braking safety while loading is guaranteed.

旁磁刹车: 最新设计的磁力产生器, 其特性为产磁。可在电源切断的同时刹车, 保证吊重时刹车绝对确保安全。

Limit switch: The limit switch device is installed where the weight is lifted on and off to make the motor to stop automatically so as to prohibit the chains from exceeding for safety.

极限开关: 吊上吊下都有极限开关装置, 使自动停止, 防止链条超出, 确保安全。

Chain: The chain shall adopt the imported FEC G80 ultra heat-treatable aluminum alloy chain. It can be safely used in poor environments such as rain, sea water and chemicals.

链条: 采用进口 FEC G80 超级加热处理合金钢链条。在雨水、海水、化学品及其他恶劣状况下使用安全无虑。

Hook: It is hot forging with perfect strength that is hard to break. The operation safety of the lower hook is ensured by its 360 degrees rotation and safety flap.

吊钩: 经热锻造, 强度绝佳, 不易断裂。下吊钩可360°旋转, 附安全舌片, 确保操作安全。

Support frame: The loading support frame consists of two steel plates, which is extremely sturdy.

支撑架: 吊重支撑架由两片钢板组合, 非常坚固。

Transformer: 24V/36V transformer device. This device is used to prohibit unexpected accidents caused by electric leakage and guarantees the safe use while raining.

变压器: 24V/36V 变压装置。操作时, 万一漏电, 可防止意外事故发生, 下雨时, 可保证安全使用。

Electromagnetic contactor: Electromagnetic contactor can be used safely under high frequency.

电磁接触器: 高效率电磁接触器。可高频率使用, 没有问题。

Inverse phases sequence protecting device: It is the special electrical installation which controls the circuit not to work in case of wiring error in the power supply.

逆相保护装置: 特殊电气装置, 当电源接线错误时, 控制电路无法动作。

Control switch: Waterproof push button is applied. It is light and durable.

按钮开关: 使用防水按钮开关, 轻便耐用。

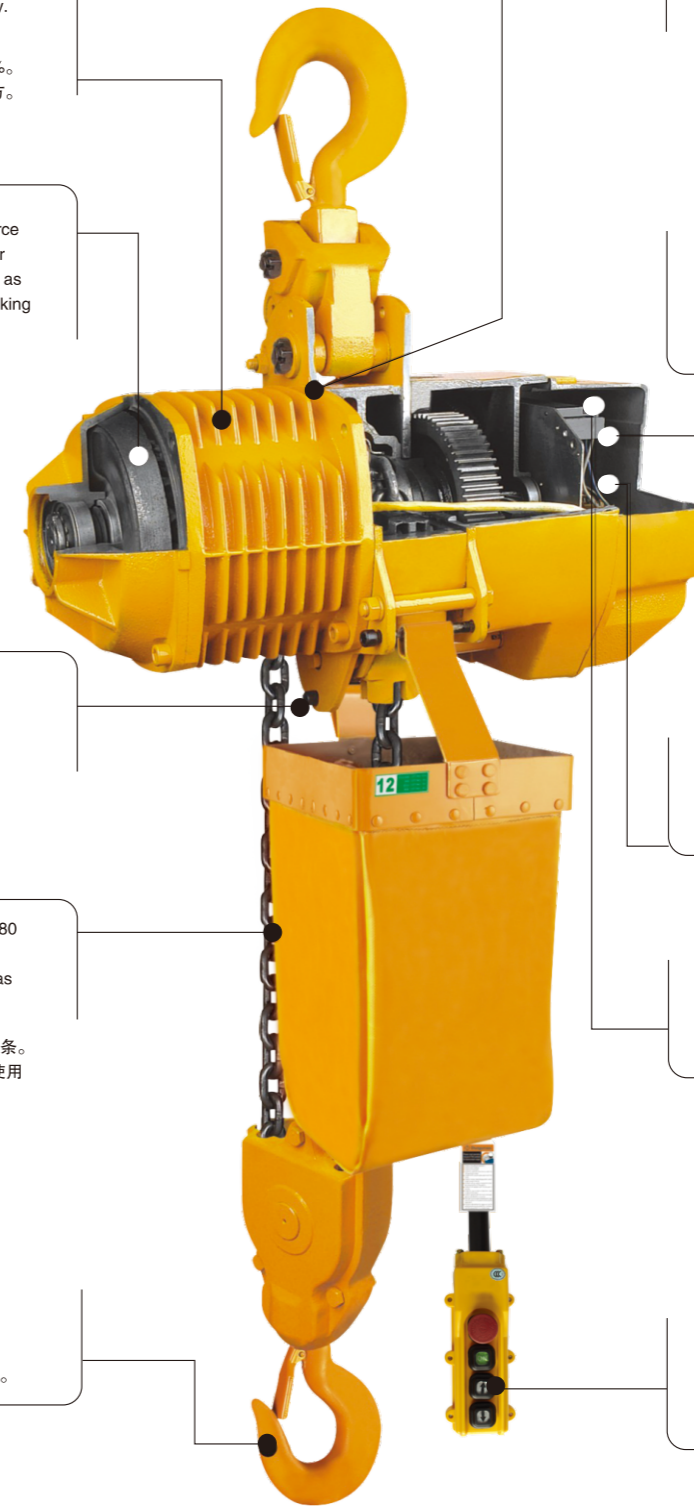

Standard Accessories: Chain bag(1) Control cable (3m) Push-button switch (1)

标准配件: 链条袋(1个) 控制电缆(3m) 按钮开关(1只)

0.5t-5t HHBB

hook Suspension type (挂钩式)

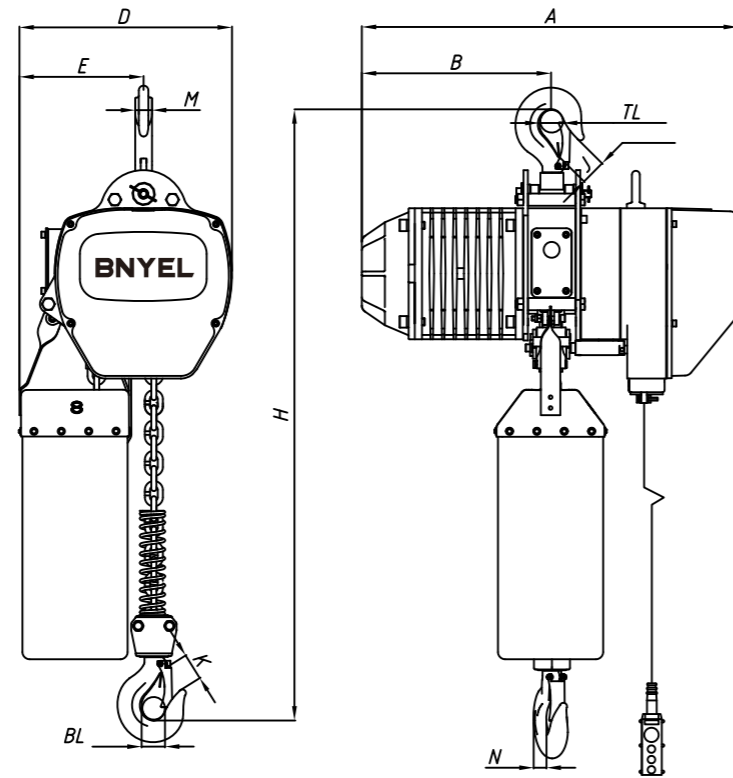
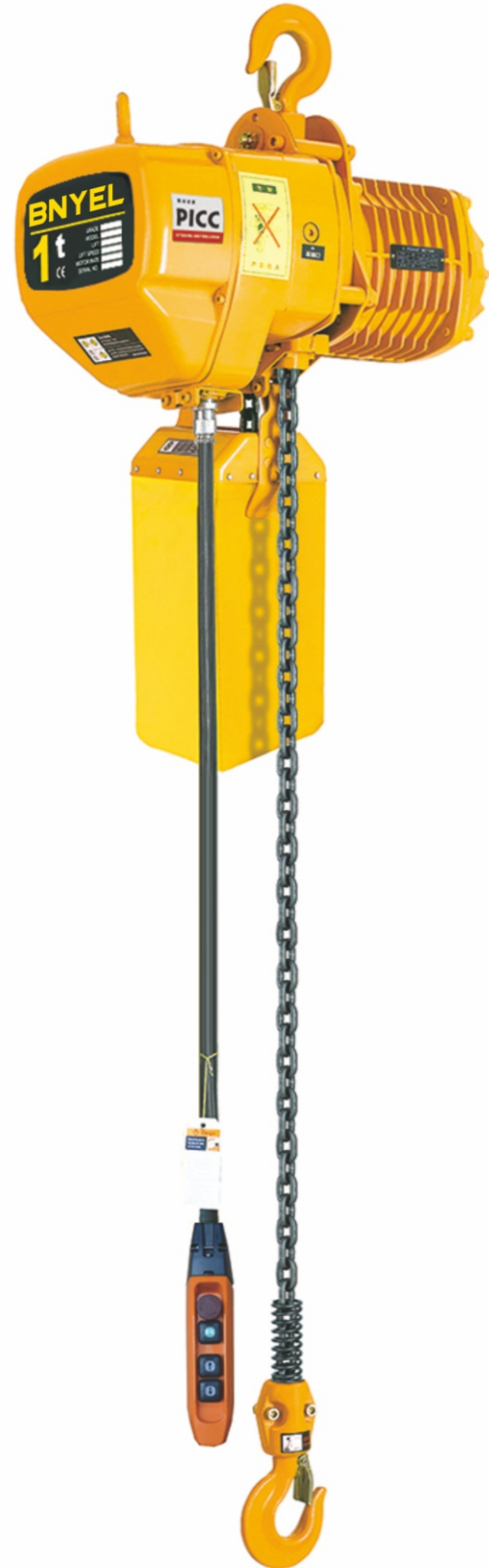

外壳:

外壳轻巧而坚固, 散热率高, 全密封性设计适合在作业条件较差的环境中使用。

逆相保护装置:

为特殊电器装置, 当电源接线错误时, 控制电路无法工作。

极限开关:

重物吊上吊下都有极限开关装置, 使电机自动停止, 以防链条超出, 确保安全。

24V/36V装置:

此装置可以实现电源切断时瞬间刹车。

链条袋:

轻巧、美观、耐用。

链条:

采用进口FEC G80超热处理合金刚链条。

Shell:

Light aluminum alloy shell be adopted, which is light but hard and fit for the use in the terrible work environment with a high heat dissipation rate and tightness design.

Inverse phase sequence protecting device:

It is the special electrical installation which controls the circuit not to work in case of wiring error in the power supply.

Limit switch:

The limit switch device is installed where the weight is lifted on and off to make the motor to stop automatically so as to prohibit the chains from exceeding for safety.

24V/36V device:

It is used to prohibit the emergencies from occurring in case of the leakage in the switch.

Side magnetic braking device:

This device shall realize the instant brake in case of the power dump.

Chain bag:

It shall be light, handsome and durable.

Chain:

The chain shall adopt the imported FEC G80 ultra heat-treatable aluminum alloy chain.

0.5t-5t HHBB SS

Single lifting speed with hook Suspension (单速挂钩式)

Specifications 规格

Capacity 额定载荷 (t)	Product Code 型号	Standard Lift Height 标准 起升高度 (m)	Lifting Motor 起升电机		Load Chain 载重链 Diameter x Falls 载重链直径 x 回数 (mm)	Voltage 电压 (v)	Test Load 实验载荷 (t)	Net Weight 净重 (kg)		
			Lifting Speed 起升速度(m/min)	Output 输出功率 (kW)						
500kg	HHBB0.5-01SS	3	7.2	8.6	0.75	3 (Phase)	750kg	42		
1000kg	HHBB01-01SS		6.8	8.2	1.5					
	HHBB01-02SS		3.6	4.3	0.75		1250kg	59		
							49			
2000kg	HHBB02-01SS		6.6	7.9	3.0	220-440 (V)	2500kg	109		
	HHBB02-02SS		3.4	4.1	1.5					68
3000kg	HHBB03-01SS		5.4	6.5	3.0	50/60 (Hz)	3750kg	113		
	HHBB03-02SS		3.4	4.1	1.5					129
	HHBB03-03SS		2.3	2.7	1.5					90
5000kg	HHBB05-02SS		2.7	3.2	3.0		6250kg	138		

Dimensions (mm) 尺寸

Capacity 额定载荷 (t)	Product Code 型号	H	A	B	D	E	TL	J	BL	K	M	N	R	T
500kg	HHBB0.5-01SS	550	460	230	280	160	Φ35	25	Φ35	25	17	17		
1000kg	HHBB01-01SS	650	520	260	300	176	Φ40	31	Φ40	31	22	22		
	HHBB01-02SS	670	460	230	280	205								
2000kg	HHBB02-01SS	800	615	295	430	265	Φ47	40	Φ47	38	30	30		
	HHBB02-02SS	835	520	260	300	236								
3000kg	HHBB03-01SS	845	615	295	430	265	Φ58	47	Φ58	47	36	36		
	HHBB03-02SS	950				320								
	HHBB03-03SS	1000				205								
5000kg	HHBB05-02SS	1030	615	295	430	325	Φ60	48	Φ60	48	43	43		

0.5t-5t HHBB DS

Dual lifting speed with hook Suspension (双速挂钩式)

Capacity 额定载荷 (t)	Product Code 型号	Standard Lift Height 标准 起升高度 (m)	Lifting Motor 起升电机		Load Chain 载重链 Diameter x Falls 载重链直径 x 回数 (mm)	Voltage 电压 (v)	Test Load 实验载荷 (t)	Net Weight 净重 (kg)		
			Lifting Speed 起升速度(m/min)	Output 输出功率 (kW)						
500kg	HHBB0.5-01DS	3	7.2/2.4	8.6/2.9	0.75/0.25	3 (Phase)	750kg	52		
1000kg	HHBB01-01DS		6.8/2.3	8.2/2.7	1.5/0.5					
	HHBB01-02DS		3.6/1.2	4.3/1.4	0.75/0.25		1250kg	69		
							59			
2000kg	HHBB02-01DS		6.6/2.2	7.9/2.6	3.0/1.0	220-440 (V)	2500kg	129		
	HHBB02-02DS		3.4/1.2	4.1/1.4	1.5/0.5					78
3000kg	HHBB03-01DS		5.4/1.8	6.5/2.2	3.0/1.0	50/60 (Hz)	3750kg	133		
	HHBB03-02DS		3.4/1.2	4.1/1.4	1.5/0.5					149
	HHBB03-03DS		2.3/0.8	2.7/0.92	1.5/0.5					100
5000kg	HHBB05-02DS		2.7/0.9	3.2/1.1	3.0/1.0		6250kg	158		

Dimensions (mm) 尺寸

Capacity 额定载荷 (t)	Product Code 型号	H	A	B	D	E	TL	J	BL	K	M	N	R	T
500kg	HHBB0.5-01DS	550	545	260	280	160	Φ35	25	Φ35	25	17	17		
1000kg	HHBB01-01DS	650	582	280	300	176	Φ40	31	Φ40	31	22	22		
	HHBB01-02DS	670	545	260	280	205								
2000kg	HHBB02-01DS	800	670	313	430	265	Φ47	40	Φ47	38	30	30		
	HHBB02-02DS	835	582	280	300	236								
3000kg	HHBB03-01DS	845	670	313	430	265	Φ58	47	Φ58	47	36	36		
	HHBB03-02DS	950				320								
	HHBB03-03DS	1000				205								
5000kg	HHBB05-02DS	1030	670	313	430	325	Φ60	48	Φ60	48	43	43		

0.5t-5t HHBB

Motorized trolley type (挂钩式)

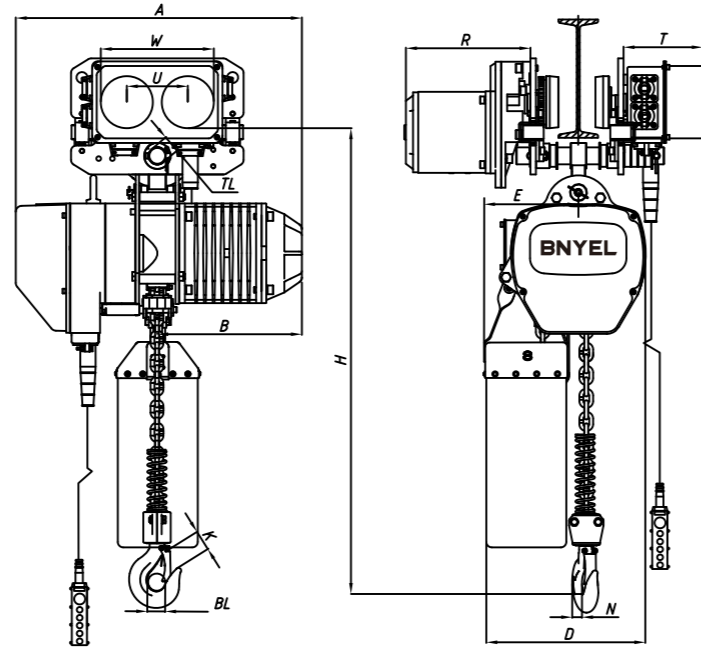

●本机采用高强度铝合金机体，外形美观，机体紧凑，体积小，重量轻。采用二级齿轮传动，高速级为斜齿轮传动。因而传动平稳，噪音小。

●零部件强度高

●本机主要零部件均采用高合金钢材料，并且经过独到特殊处理工艺加工，具有强度高，耐磨性好等特点，上下吊钩采用高强度合金钢制作，经强化热处理后具有很高韧性，即使机体因超载引起破坏，吊钩也只会塑性变形，不会发生脆性断裂。

●Our Hoist is made of high-strength alloy, consists of beautiful appearance, compact mechanism, small in size and light weight. And we use double-gear drive, helical gear drive when it works under fast speed, so that the hoists can drive smoothly with low noise

●The Components and parts of our hoists in high-strength as well

●The high-strength alloy on the components and parts is going through multiple special technology for heating processing, so that it is high-strength and good abrasion performance; the up and bottom hooks of our hoists are made of high-strength alloy too, which is good in ductility cause of strengthen heating processing, it means even the hoist is damaged by overload, the hook will only been plastic distorted and never been brittle fractured.

0.5t-5t HHBB SM

Single lifting speed with Motorized trolley (单速带电动小车式)

Specifications 规格

Capacity 额定载荷 (t)	Product Code 型号	Standard Lift Height 标准 起升高度 (m)	Lifting Motor 起升电机			Travelling Motor 运行电机			Load Chain 载重链 载重链直径 x 回数 (mm)	Flange Width 工字钢 (mm)	Voltage 电压 (v)	Test Load 实验载荷 (t)	Net Weight 净重 (kg)	
			Lifting Speed 起升速度(m/min)		Output 输出功率 (kW)	Traversing Speed 运行速度(m/min)		Output 输出功率 (kW)						
			50Hz	60Hz	50Hz	60Hz	50Hz							
500kg	HHBB0.5-01SM	3	7.2	8.6	0.75	20 (10)	24 (12)	0.4	Φ6.3 x 1	70-130	3 (Phase) 220-440 (V) 50/60 (Hz)	750kg	83	
1000kg	HHBB01-01SM		6.8	8.2	1.5				Φ7.1 x 1	80-160		1250kg	100	
	HHBB01-02SM		3.6	4.3	0.75				Φ6.3 x 2	82-178		2500kg	90	
2000kg	HHBB02-01SM		6.6	7.9	3.0				Φ10.0 x 1	100-180		3750kg	158	
	HHBB02-02SM		3.4	4.1	1.5				Φ7.1 x 2					174
3000kg	HHBB03-01SM		5.4	6.5	3.0				Φ11.2 x 1	110-180		6250kg	220	
	HHBB03-02SM		3.4	4.1	1.5				Φ10.0 x 2					174
	HHBB03-03SM		2.3	2.7	1.5				Φ7.1 x 3					190
5000kg	HHBB05-02SM		2.7	3.2	3.0				0.75	Φ11.2 x 2		110-180	6250kg	220

Dimensions (mm) 尺寸

Capacity 额定载荷 (t)	Product Code 型号	H	A	B	D	E	TL	BL	K	N	W	U	R	T
500kg	HHBB0.5-01SM	630	460	230	280	160	Φ35	Φ35	25	17	162	100		150
1000kg	HHBB01-01SM	650	520	260	300	176	Φ40	Φ40	31	22	206	111		231
	HHBB01-02SM	695	460	230	280	205					206	111		230
2000kg	HHBB02-01SM	770	615	295	430	265	Φ47	Φ47	38	30	237	127	142	231
	HHBB02-02SM	815	520	260	300	236					265	140		
3000kg	HHBB03-01SM	830	615	295	430	265	Φ58	Φ58	47	36	265	140		231
	HHBB03-02SM	930				320								
	HHBB03-03SM	940				520								
5000kg	HHBB05-02SM	1015	615	295	430	325	Φ60	Φ60	48	43	296	156		

0.5t-5t HHBB DM

Dual lifting speed with Motorized trolley (双速带电动小车式)

Specifications 规格

Capacity 额定载荷 (t)	Product Code 型号	Standard Lift Height 标准 起升高度 (m)	Lifting Motor 起升电机			Travelling Motor 运行电机			Load Chain 载重链 载重链直径 x 回数 (mm)	Flange Width 工字钢 (mm)	Voltage 电压 (v)	Test Load 实验载荷 (t)	Net Weight 净重 (kg)	
			Lifting Speed 起升速度(m/min)		Output 输出功率 (kW)	Traversing Speed 运行速度(m/min)		Output 输出功率 (kW)						
			50Hz	60Hz	50Hz	60Hz	50Hz							
500kg	HHBB0.5-01DM	3	7.2/2.4	8.6/2.9	0.75/0.25	20 (10)	24 (12)	0.4	Φ6.3 x 1	70-130	3 (Phase) 220-440 (V) 50/60 (Hz)	750kg	93	
1000kg	HHBB01-01DM		6.8/2.3	8.2/2.8	1.5/0.5				Φ7.1 x 1	80-160		1250kg	110	
	HHBB01-02DM		3.6/1.2	4.3/1.4	0.75/0.25				Φ6.3 x 2	82-178		2500kg	100	
2000kg	HHBB02-01DM		6.6/2.2	7.9/2.6	3.0/1.0				Φ10.0 x 1	100-180		3750kg	178	
	HHBB02-02DM		3.4/1.2	4.1/1.4	1.5/0.5				Φ7.1 x 2					127
3000kg	HHBB03-01DM		5.4/1.8	6.75/2.3	3.0/1.0				Φ11.2 x 1	110-180		6250kg	240	
	HHBB03-02DM		3.4/1.2	4.1/1.4	1.5/0.5				Φ10.0 x 2					194
	HHBB03-03DM		2.3/0.8	2.7/0.92	1.5/0.5				Φ7.1 x 3					210
5000kg	HHBB05-02DM		2.7/0.9	3.2/1.1	3.0/1.0				0.75	Φ11.2 x 2		110-180	6250kg	240

Dimensions (mm) 尺寸

Capacity 额定载荷 (t)	Product Code 型号	H	A	B	D	E	TL	BL	K	N	W	U	R	T
500kg	HHBB0.5-01DM	630	545	260	280	160	Φ35	Φ35	25	17	160	100		150
1000kg	HHBB01-01DM	650	582	280	300	176	Φ40	Φ40	31	22	206	111		231
	HHBB01-02DM	695	545	260	280	205					206	111		230
2000kg	HHBB02-01DM	770	670	313	430	265	Φ47	Φ47	38	30	237	127	142	231
	HHBB02-02DM	815	582	280	300	236					265	140		
3000kg	HHBB03-01DM	830	670	313	430	265	Φ58	Φ58	47	36	265	140		231
	HHBB03-02DM	930				320								
	HHBB03-03DM	940				582								
5000kg	HHBB05-02DM	1015	670	313	430	325	Φ60	Φ60	48	43	296	156		

0.5t-5t HHBB SP

Single lifting speed with Plain trolley (单速手动小车式)

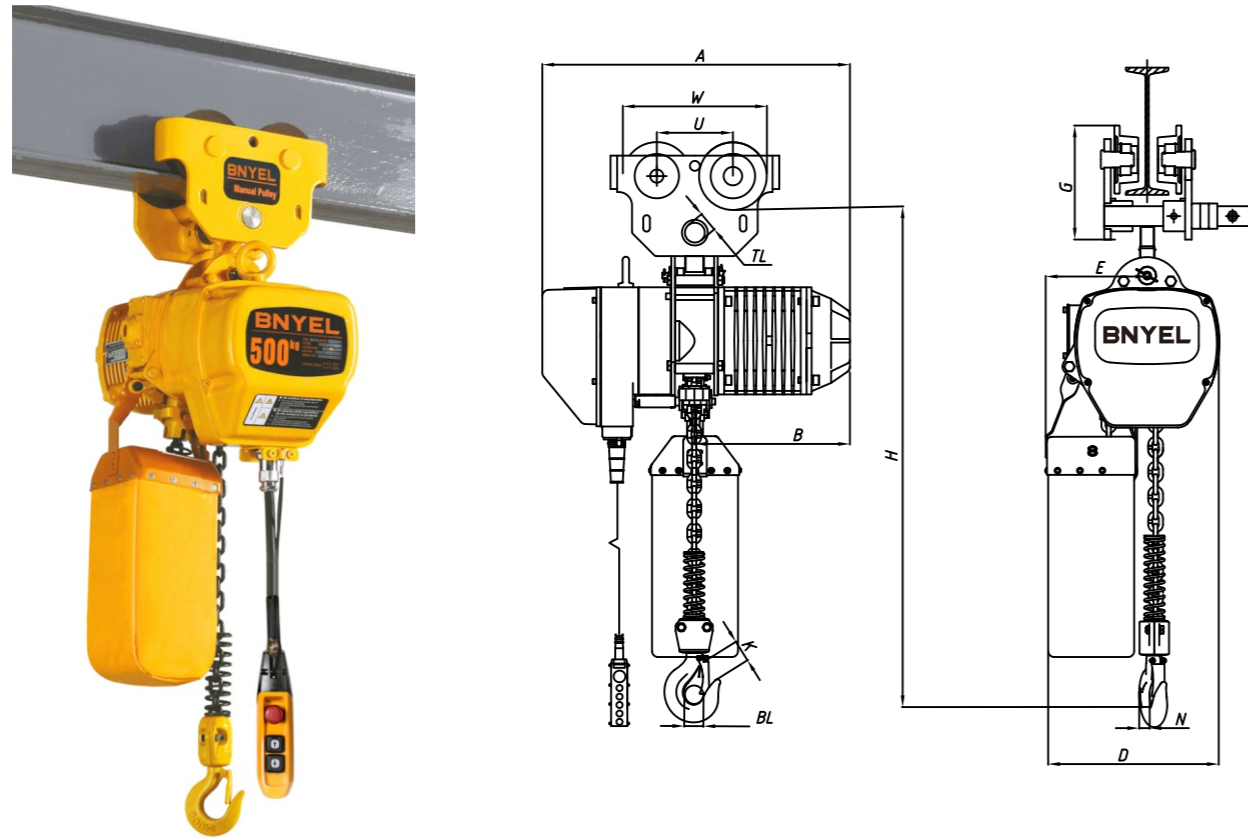

Specifications 规格

Capacity 额定载荷 (t)	Product Code 型号	Standard Lift Height 标准起升高度 (m)	Lifting Motor 起升电机		Load Chain 载重链 Diameter x Falls 载重链直径 x 回数 (mm)	Flange Width 工字钢 (mm)	Voltage 电压 (v)	Test Load 实验载荷 (t)	Net Weight 净重 (kg)	
			Lifting Speed 起升速度 (m/min)							Output 输出功率 (kW)
			50Hz	60Hz						
500kg	HHBB0.5-01SP		7.2	8.6	0.75	Φ6.3 x 1	70-130	750kg	48	
1000kg	HHBB01-01SP		6.8	8.2	1.5	Φ7.1 x 1	80-160	3 (Phase)	1250kg	69
1000kg	HHBB01-02SP		3.6	4.3	0.75	Φ6.3 x 2			59	
2000kg	HHBB02-01SP	3	6.6	7.9	3.0	Φ10.0 x 1	82-178	220-440 (V)	2500kg	124
	HHBB02-02SP		3.4	4.1	1.5	Φ7.1 x 2			83	
3000kg	HHBB03-01SP		5.4	6.5	3.0	Φ11.2 x 1	100-180	50/60 (Hz)	3750kg	138
	HHBB03-02SP		3.4	4.1		Φ10.0 x 2				154
	HHBB03-03SP		2.3	2.7	1.5	Φ7.1 x 3				115
5000kg	HHBB05-02SP		2.7	3.2	3.0	Φ11.2 x 2	110-180		6250kg	176

Dimensions (mm) 尺寸

Capacity 额定载荷 (t)	Product Code 型号	H	A	B	D	E	TL	BL	K	N	W	U	G	T
500kg	HHBB0.5-01SP	580	460	230	280	160	Φ35	Φ35	25	17	163	91	130	
1000kg	HHBB01-01SP	635	520	260	300	176	Φ40	Φ40	31	22	221	115	170	
	HHBB01-02SP	670	460	230	280	205								
2000kg	HHBB02-01SP	764	615	295	430	265	Φ47	Φ47	38	30	265	135	205	/
	HHBB02-02SP	800	520	260	300	236								
3000kg	HHBB03-01SP	854	615	295	430	265	Φ58	Φ58	47	36	305	157	236	
	HHBB03-02SP	960				320								
	HHBB03-03SP	968				520								260
5000kg	HHBB05-02SP	1007	615	295	430	325	Φ60	Φ60	48	43	332	178	280	

7.5t HHBB SM / 7.5t HHBB DM

Single lifting speed with Motorized trolley (单速带电动小车式)

Dual lifting speed with Motorized trolley (双速带电动小车式)

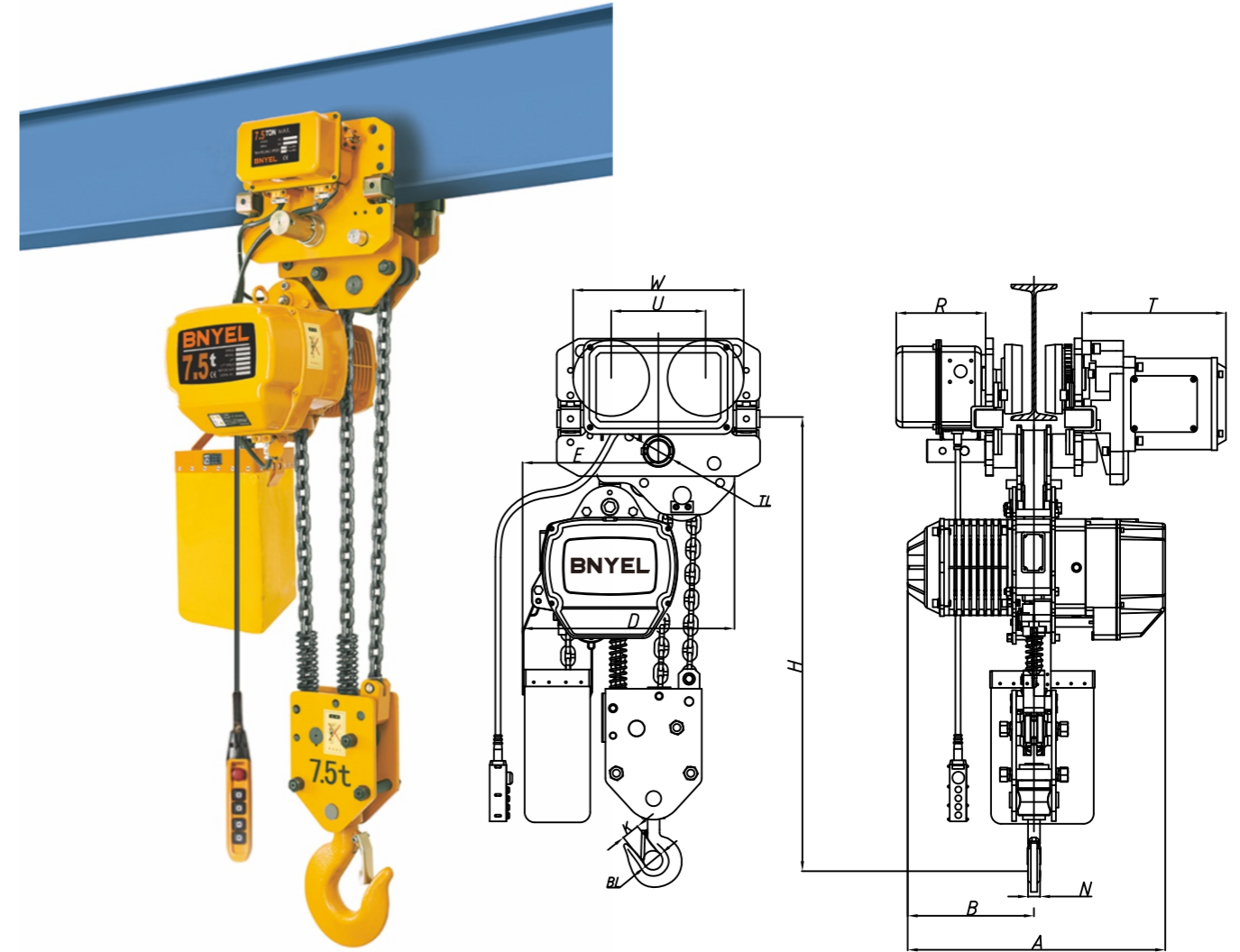

Specifications 规格

Capacity 额定载荷 (t)	Product Code 型号	Standard Lift Height 标准起升高度 (m)	Lifting Motor 起升电机		Travelling Motor 运行电机		Load Chain 载重链 Diameter x Falls 载重链直径 x 回数 (mm)	Flange Width 工字钢 (mm)	Voltage 电压 (v)	Test Load 实验载荷 (t)	Net Weight 净重 (kg)		
			Lifting Speed 起升速度 (m/min)		Traversing Speed 运行速度 (m/min)								
			50Hz	60Hz	50Hz	60Hz							
7500kg	HHBB7.5-03SM	3	1.8	2.2	3.0	10	12	0.75	Φ11.2 x 3	120-180	3 Phase 220-440 v 50/60	9375kg	257
	1.8/0.6		2.2/0.7	3.0/1.0	277								

Dimensions (mm) 尺寸

Capacity 额定载荷 (t)	Product Code 型号	H	A	B	D	E	TL	BL	K	N	W	U	R	T
7500kg	HHBB7.5-03SM	1200	615	295	505	320	Φ54	Φ85	80	55	295	156	142	231
	HHBB7.5-03DM		670	313										

10t HHBB SS / 10t HHBB DS

Single lifting speed with hook Suspension
(单速挂钩式)

Dual lifting speed with hook Suspension
(双速挂钩式)

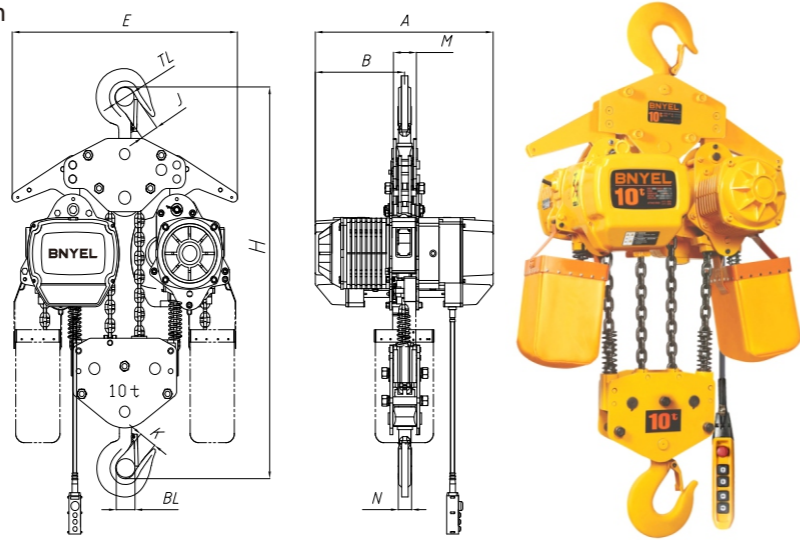

Specifications 规格

Capacity 额定载荷 (t)	Product Code 型号	Standard Lift Height 标准 起升高度 (m)	Lifting Motor 起升电机			Load Chain 载重链 Diameter x Falls 载重链直径 x 回数 (mm)	Voltage 电压 (v)	Test Load 实验载荷 (t)	Net Weight 净重 (kg)
			Lifting Speed 起升速度(m/min)		Output 输出功率 (kW)				
			50Hz	60Hz					
10000kg	HHBB10-04SS	3	2.7	3.2	3.0 x 2	Φ11.2 x 4	3 Phase 220-440 v 50/60 Hz	12500kg	295
	HHBB10-04DS		2.7/0.9	3.2/1.1	3.0/1.0 x 2				335

Dimensions (mm) 尺寸

Capacity 额定载荷 (t)	Product Code 型号	H	A	B	D	E	TL	J	BL	M	K	N	W	U
10000kg	HHBB10-04SS	1400	630	315	/	890	Φ85	80	Φ85	104	80	55	/	/
	HHBB10-04DS		685	352										

10t HHBB SM / 10t HHBB DM

Single lifting speed with Motorized trolley
(单速带电动小车式)

Dual lifting speed with Motorized trolley
(双速带电动小车式)

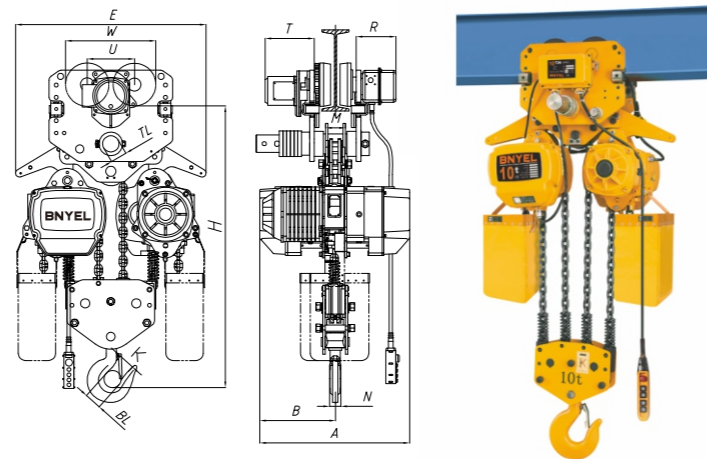

Specifications 规格

Capacity 额定载荷 (t)	Product Code 型号	Standard Lift Height 标准 起升高度 (m)	Lifting Motor 起升电机			Travelling Motor 运行电机			Load Chain 载重链 Diameter x Falls 载重链直径 x 回数 (mm)	Flange Width 工字钢 (mm)	Voltage 电压 (v)	Test Load 实验载荷 (t)	Net Weight 净重 (kg)
			Lifting Speed 起升速度(m/min)		Output 输出功率 (kW)	Traversing Speed 运行速度(m/min)		Output 输出功率 (kW)					
			50Hz	60Hz		50Hz	60Hz						
10000kg	HHBB10-04SM	3	2.7	3.2	3.0 x 2	10	12	0.75	Φ11.2 x 4	3 Phase 220-440 v 50/60Hz	12500kg	423	
	HHBB10-04DM		2.7/0.9	3.2/1.1	3.0/1.0 x 2							463	

Dimensions (mm) 尺寸

Capacity 额定载荷 (t)	Product Code 型号	H	A	B	E	TL	BL	M	K	N	W	U	R	T
10000kg	HHBB10-04SM	1190	630	315	890	Φ70	Φ85	85	80	55	366	191	142	231
	HHBB10-04DM		685	352										

15t - 25t HHBB SM / 15t - 25t HHBB DM

Single lifting speed with Motorized trolley (单速带电动小车式)

Dual lifting speed with Motorized trolley (双速带电动小车式)

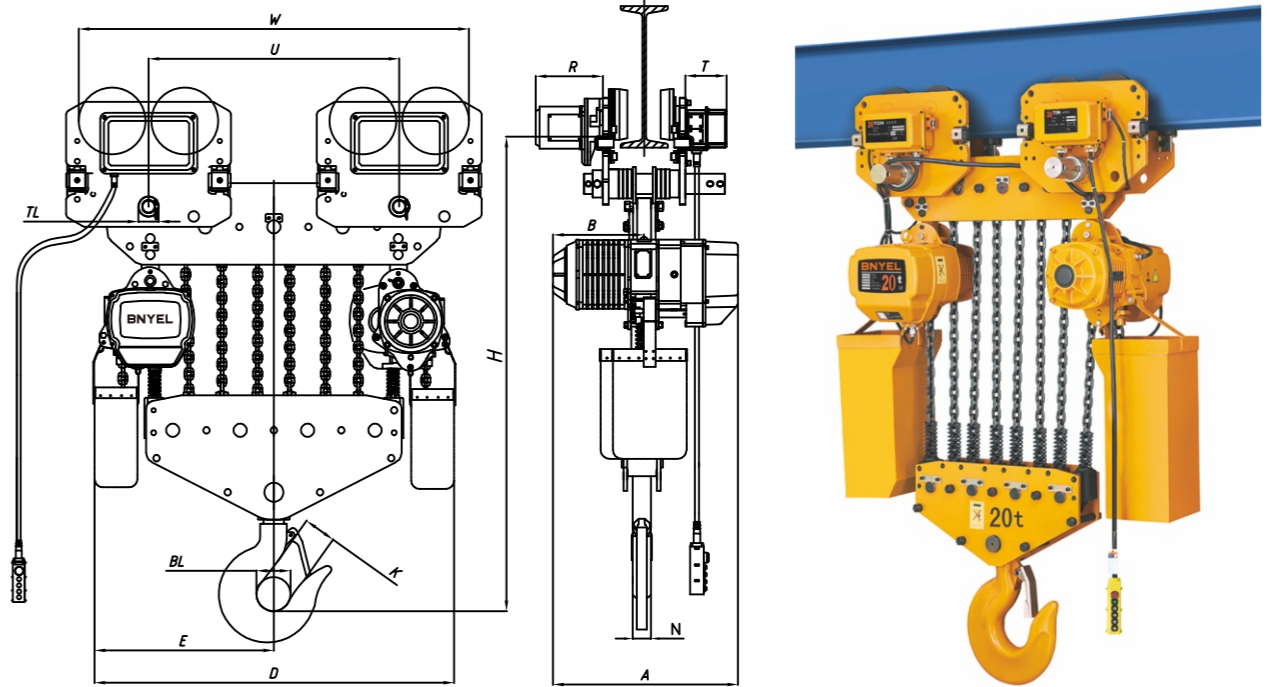

Specifications 规格

Capacity 额定载荷 (t)	Product Code 型号	Standard Lift Height 标准 起升高度 (m)	Lifting Motor 起升电机			Travelling Motor 运行电机			Load Chain 载重链 Diameter x Falls 载重链直径 x 回数 (mm)	Flange Width 工字钢 (mm)	Voltage 电压 (v)	Test Load 实验载荷 (t)	Net Weight 净重 (kg)
			Lifting Speed 起升速度(m/min)		Output 输出功率 (kW)	Traversing Speed 运行速度(m/min)		Output 输出功率 (kW)					
			50Hz	60Hz		50Hz	60Hz						
15000kg	HHBB15-06SM	3	1.8	2.2	3.0 x 2	10	12	0.75 x 2	Φ11.2 x 6	150-220	3 (Phase)	18750kg	636
20000kg	HHBB20-08SM		1.4	1.7									
25000kg	HHBB25-10SM		1.2	1.4	31250kg	836							
15000kg	HHBB15-06DM		1.8/0.6	2.2/0.7	Φ11.2 x 6	150-220	220-440 (V)	18750kg	676				
20000kg	HHBB20-08DM		1.4/0.5	1.7/0.6						25000kg	776		
25000kg	HHBB25-10DM		1.2/0.4	1.4/0.5	Φ11.2 x 10	31250kg	876						

Dimensions (mm) 尺寸

Capacity 额定载荷 (t)	Product Code 型号	H	A	B	E	TL	BL	M	K	N	W	U	R	T
15000kg	HHBB15-06SM	1310			1070	535	54	120	96	85	926	560		
20000kg	HHBB20-08SM	1470	630	315	1260	630	70	150	115	95	1106	740		
25000kg	HHBB25-10SM	1580			1450	725	70	150	115	95	1280	830	142	231
15000kg	HHBB15-06DM	1310			1070	535	54	120	96	85	926	560		
20000kg	HHBB20-08DM	1470	685	352	1260	630	70	150	115	95	1106	740		
25000kg	HHBB25-10DM	1580			1450	725	70	150	115	95	1280	830		

0.5t-10t HHBB SL

Single lifting speed ultra Low headroom (单速低净空式)



Product Features:

Maxload Ultra Low Headroom Electric Chain Hoists are designed for those applications where space is limited. The units provide smooth, quiet trouble free operation in a variety of Class III applications. The units are equipped with the following features:

- FEC G80 ultra heat-treated alloy steel chain which is suitable for rain, sea water and chemical environments.
- Choices of lug mounted push/pull, hand geared or motorized trolley drives geared limit switches for both upper and lower hook travel.
- Standard voltage is 200-440V, 3 phase.
- Capacities from 0.5ton through 10 tons.
- Sturdy steel construction
- Direct acting motor brakes

Maxload 低净空环链电动葫芦专为操作空间受限制而设计的机种，可达扬程最大化，并争取较大的操作高度。

具备以下特点：

- 使用FEC G80超热处理合金钢进口链条，适用于雨水，海水以及化学环境中。
- 固定式以及电动运行式，供选择；
- 标配限位开关，急停按钮，起吊更安全；
- 电压区间：200-440V；
- 载重为0.5-10吨。

0.5t-10t HHBB DL

Dual lifting speed ultra Low headroom (双速低净空式)

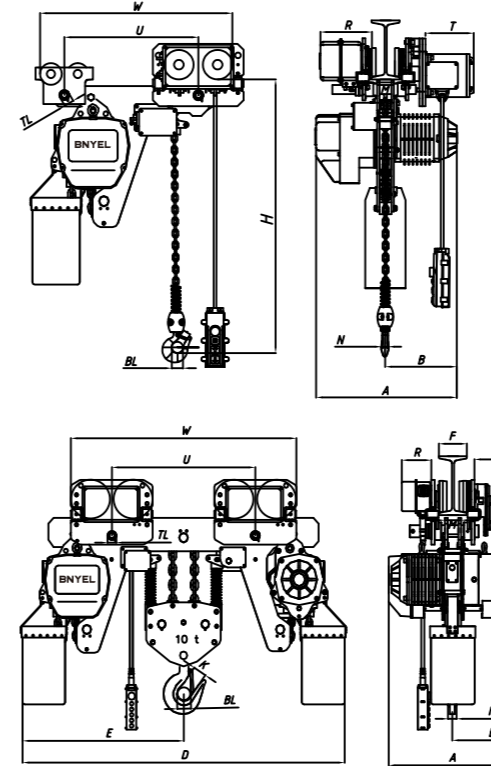

Specifications 规格

Capacity 额定载荷 (t)	Product Code 型号	Standard Lift Height 标准 起升高度 (m)	Lifting Motor 起升电机			Travelling Motor 运行电机			Load Chain 载重链 Diameter x Falls 载重链直径 x 回数 (mm)	Flange Width 工字钢 (mm)	Voltage 电压 (v)	Test Load 实验载荷 (t)	Net Weight 净重 (kg)
			Lifting Speed 起升速度(m/min)		Output 输出功率 (kW)	Traversing Speed 运行速度(m/min)		Output 输出功率 (kW)					
			50Hz	60Hz		50Hz	60Hz						
500kg	HHBB0.5-01SL		7.2	8.6	0.75				70-130		750kg	111	
1000kg	HHBB01-01SL		6.8	8.2	1.5				80-160		1250kg	128	
	HHBB01-02SL		3.6	4.3	0.75							118	
2000kg	HHBB02-01SL		6.6	7.9		20 (10)	24 (12)	0.4	82-178	3 (Phase)	2500kg	207	
	HHBB02-02SL		3.4	4.1	1.5								
3000kg	HHBB03-01SL	3	5.4	6.5	3.0				100-180	220-440 (V)	3750kg	231	
	HHBB03-02SL		3.4	4.1								247	
	HHBB03-03SL		2.2	2.6	1.5							208	
5000kg	HHBB05-02SL		2.7	3.4	3.0					50/60 (Hz)	6250kg	284	
7500kg	HHBB7.5-03SL		1.8	2.2		10	12	0.75	120-180		9375kg	321	
1000kg	HHBB10-04SL		2.7	3.2	3.0 x 2							150-220	

Dimensions (mm) 尺寸

Capacity 额定载荷 (t)	Product Code 型号	H	A	B	D	TL	BL	K	M	N	W	U	R	T	
500kg	HHBB0.5-01SL	440	460	230				35	25	52	17	585	400		
1000kg	HHBB01-01SL	480	520	260				31	40	31	56	22	630	445	
	HHBB01-02SL	410	460	230			50				24	595	410		
2000kg	HHBB02-01SL	570	615	295				47	38	30	66		720	505	
	HHBB02-02SL	535	520	260			56					665	445		
3000kg	HHBB03-01SL	640	615	295	/	36	58	47	47	36	73		775	526	
	HHBB03-02SL	685										66		750	503
	HHBB03-03SL	900									520	260		65	65
5000kg	HHBB05-02SL	740	615	295		43	60	48	73	43	825		541		
7500kg	HHBB7.5-03SL	890										85	80		55
10000kg	HHBB10-04SL	880	630	315	1640	54			85	85	926	630			

Specifications 规格

Capacity 额定载荷 (t)	Product Code 型号	Standard Lift Height 标准 起升高度 (m)	Lifting Motor 起升电机			Travelling Motor 运行电机			Load Chain 载重链 Diameter x Falls 载重链直径 x 回数 (mm)	Flange Width 工字钢 (mm)	Voltage 电压 (v)	Test Load 实验载荷 (t)	Net Weight 净重 (kg)
			Lifting Speed 起升速度(m/min)		Output 输出功率 (kW)	Traversing Speed 运行速度(m/min)		Output 输出功率 (kW)					
			50Hz	60Hz		50Hz	60Hz						
500kg	HHBB0.5-01DL		7.2/2.4	8.6/2.9	0.75/0.25				70-130		750kg	123	
1000kg	HHBB01-01DL		6.8/2.3	8.2/2.8	1.5/0.5				80-160		1250kg	138	
	HHBB01-02DL		3.6/1.2	4.3/1.4	0.75/0.25							130	
2000kg	HHBB02-01DL		6.6/2.2	7.9/2.6	3.0/1.0	20 (10)	24 (12)	0.4	82-178	3 (Phase)	2500kg	227	
	HHBB02-02DL		3.4/1.2	4.3/1.4	1.5/0.5								
3000kg	HHBB03-01DL	3	5.4/1.8	6.5/2.2	3.0/1.0				100-180	220-440 (V)	3750kg	251	
	HHBB03-02DL		3.4/1.2	4.1/1.4								267	
	HHBB03-03DL		2.3/0.8	2.7/0.92	1.5/0.5							218	
5000kg	HHBB05-02DL		2.7/0.9	3.4/1.1	3.0/1.0					50/60 (Hz)	6250kg	304	
7500kg	HHBB7.5-03DL		1.8/0.6	2.2/0.7		10	12	0.75	120-180		9375kg	341	
1000kg	HHBB10-04DL		2.7/0.9	3.2/1.1	3.0/1.0 x 2							150-220	

Dimensions (mm) 尺寸

Capacity 额定载荷 (t)	Product Code 型号	H	A	B	D	TL	BL	K	M	N	W	U	R	T	
500kg	HHBB0.5-01DL	440	545	260				35	25	52	17	585	400		
1000kg	HHBB01-01DL	480	582	280				31	40	31	56	22	630	445	
	HHBB01-02DL	410	545	260			50				24	595	410		
2000kg	HHBB02-01DL	570	670	313				47	38	30	66		720	505	
	HHBB02-02DL	535	582	280			56					665	445		
3000kg	HHBB03-01DL	640	670	313	/	36	58	47	47	36	73		775	526	
	HHBB03-02DL	685										66		750	503
	HHBB03-03DL	900									582	280		65	65
5000kg	HHBB05-02DL	740	615	295		43	60	48	73	43	825		541		
7500kg	HHBB7.5-03DL	890										85	80		55
10000kg	HHBB10-04DL	880	630	315	1640	54			85	85	926	630			

0.5t-5t HHER SM

Single lifting speed with Motorized trolley (单速带电动小车式)

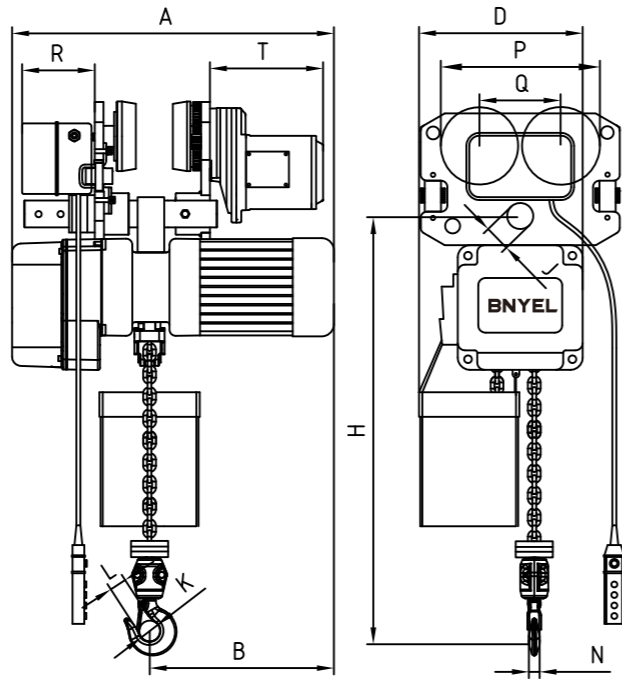

Maxload ER Serious Electric Chain Hoist Designed with strength and stability in mind, the body is both lightweight and tough with external motor fan cools the hoist during heavy use. The electromagnetic brake generates strong braking forces and holds the load securely. A sensor will cut the power in the case of overheating.

Specifications 规格

Capacity 额定载荷 (t)	Product Code 型号	Standard Lift Height 标准起升高度 (m)	Lifting Motor 起升电机			Travelling Motor 运行电机			Load Chain 载重链 Diameter x Falls 载重链直径 x 回数 (mm)	Flange Width 工字钢 (mm)	Voltage 电压 (v)	Test Load 实验载荷 (t)	Net Weight 净重 (kg)
			Lifting Speed 起升速度 (m/min)		Output 输出功率 (kW)	Travelling Speed 运行速度 (m/min)		Output 输出功率 (kW)					
			50Hz	60Hz		50Hz	60Hz						
1000kg	HHER01-01SM		7.2	8.6	1.5	20 (10)	24 (12)	0.4	Φ8.0 x 1	80-160	220-440 (V)	1250kg	96
2000kg	HHER02-01SM		5.4	6.5	3.0				100-180	Φ10.0 x 1		82-178	2500kg
	HHER02-02SM	3.6	4.3	1.5	Φ8.0 x 2	196							
3000kg	HHER03-01SM	3	5.4	6.5	3.0	3	3750kg	Φ11.2 x 1	110-180	50/60 (HZ)	3750kg	205	
	HHER03-02SM		2.8	3.4	1.5			Φ10.0 x 2			159		
	HHER03-03SM		1.8	2.2	1.5			Φ8.0 x 3			6250kg	244	
5000kg	HHER05-02SM		2.7	3.2	3.0		0.75	Φ11.2 x 2					

Dimensions (mm) 尺寸

Capacity 额定载荷 (t)	Product Code 型号	H	A	B	D	J	K	L	N	R	T	P	Q	M
1000kg	HHER01-01SM	460	595	320	300	Φ31	Φ40	31	24			206	111	
2000kg	HHER02-01SM	560	645	330	320	Φ36	Φ49	35	30	142	231	237	127	
	HHER02-02SM	660	595	320	300									
3000kg	HHER03-01SM	710	785	395	465	Φ43	Φ59	42	35			265	140	
	HHER03-02SM	680	645	330	320									
5000kg	HHER05-02SM	940	785	395	465	Φ54	Φ60	45	43			296	156	

0.5t-5t HHER SS

Single lifting speed with hook Suspension (单速挂钩式)

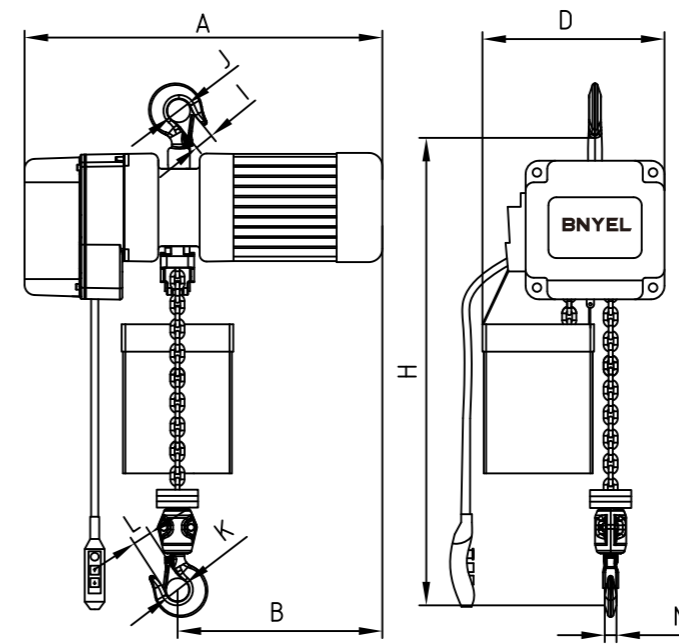

- 铝制机体
设计时，考虑到了强度和稳定性。机体既轻又坚韧。
- 排气扇
在频繁使用过程中，铝制外壳与排气扇有效地冷却葫芦。
- 电磁制动器
电磁制动器产生强烈的制动力，保持着安全地负载
- 过热保护器
一旦热量超过，传感器将切断电源
- 限位开关
当达到最高点或最低点，限位开关将关闭电机

Specifications 规格

Capacity 额定载荷 (t)	Product Code 型号	Standard Lift Height 标准起升高度 (m)	Lifting Motor 起升电机			Travelling Motor 运行电机			Load Chain 载重链 Diameter x Falls 载重链直径 x 回数 (mm)	Flange Width 工字钢 (mm)	Voltage 电压 (v)	Test Load 实验载荷 (t)	Net Weight 净重 (kg)
			Lifting Speed 起升速度 (m/min)		Output 输出功率 (kW)	Travelling Speed 运行速度 (m/min)		Output 输出功率 (kW)					
			50Hz	60Hz		50Hz	60Hz						
1000kg	HHER01-01SS		7.2	8.6	1.5	20	24	0.4	Φ8.0 x 1	220-440 (V)	1250kg	55	
2000kg	HHER02-01SS		5.4	6.5	3.0				100-180		Φ10.0 x 1	82-178	2500kg
	HHER02-02SS	3.6	4.3	1.5	Φ8.0 x 2	196							
3000kg	HHER03-01SS	3	5.4	6.5	3.0	3	3750kg	Φ11.2 x 1	110-180	50/60 (HZ)	3750kg	135	
	HHER03-02SS		2.8	3.4	1.5			Φ10.0 x 2			144		
	HHER03-03SS		1.8	2.2	1.5			Φ8.0 x 3			98		
5000kg	HHER05-02SS		2.7	3.2	3.0		0.75	Φ11.2 x 2			6250kg	162	

Dimensions (mm) 尺寸

Capacity 额定载荷 (t)	Product Code 型号	H	A	B	D	J	K	L	N	I	T	P	Q	M
1000kg	HHER01-01SS	460	595		300	Φ31	Φ40	31	24	40				
2000kg	HHER02-01SS	560	645	320	320	Φ36	Φ49	35	30	47				
	HHER02-02SS	660	595	300										
3000kg	HHER03-01SS	710	785	395	465	Φ43	Φ59	42	35	58				
	HHER03-02SS	680	645	330	320									
5000kg	HHER05-02SS	940	785	395	465	Φ54	Φ60	45	43	60				

1000kg HHST SF

Single lifting speed with hook Suspension (单速挂钩式)

Stagemaker Electric Chain Hoist 舞台吊电动葫芦 (倒吊葫芦)

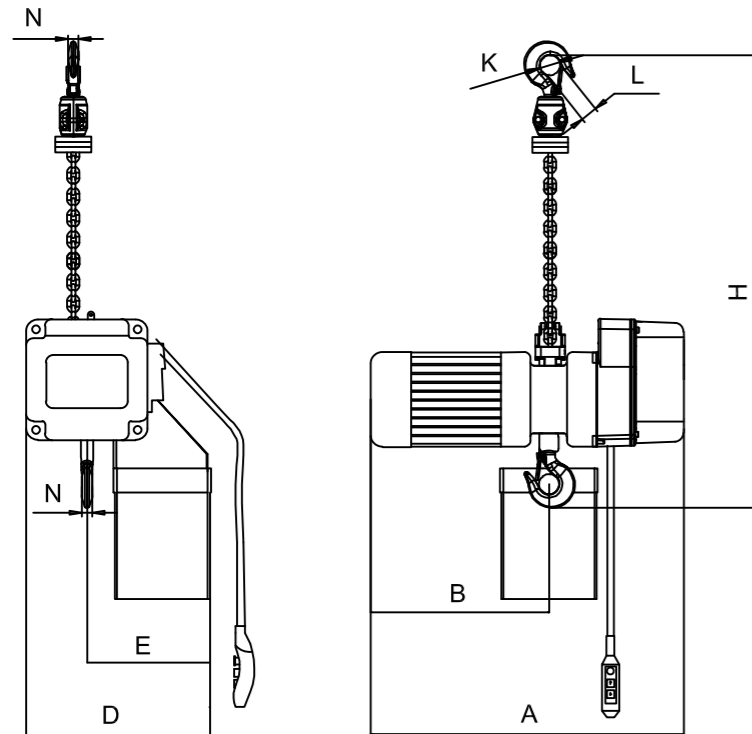

MAXLOAD conventional electric chain hoists are well accepted in various industrial fields. In explosive atmospheres of various ignitable gases and vapors, special attention must be required. In such special atmospheres, MAXLOAD HHBDB Series Electric Chain Hoists are recommended.

Specifications 规格

Capacity 额定载荷 (t)	Product Code 型号	Standard Lift Height 标准起升高度 (m)	Lifting Motor 起升电机		Load Chain 载重链 Diameter x Falls 载重链直径 x 回数 (mm)	Voltage 电压 (v)	Test Load 实验载荷 (t)	Net Weight 净重 (kg)
			Lifting Speed 起升速度(m/min)	Output 输出功率 (kW)				
1000kg	HHST01-01SF	3	7.2	8.6	1.12	3 Phase 220-440 v 50/60 Hz	1250kg	70

Dimensions (mm) 尺寸

Capacity 额定载荷 (t)	Product Code 型号	H	A	B	D	E	K	N
1000kg	HHST01-01SF	400	595	320	300	230	Φ40	24

125kg - 1000kg DMG

Dual lifting speed with Motorized trolley (双速配电动小车式)

Euro Standard Electric Chain Hoist 欧式环链电动葫芦

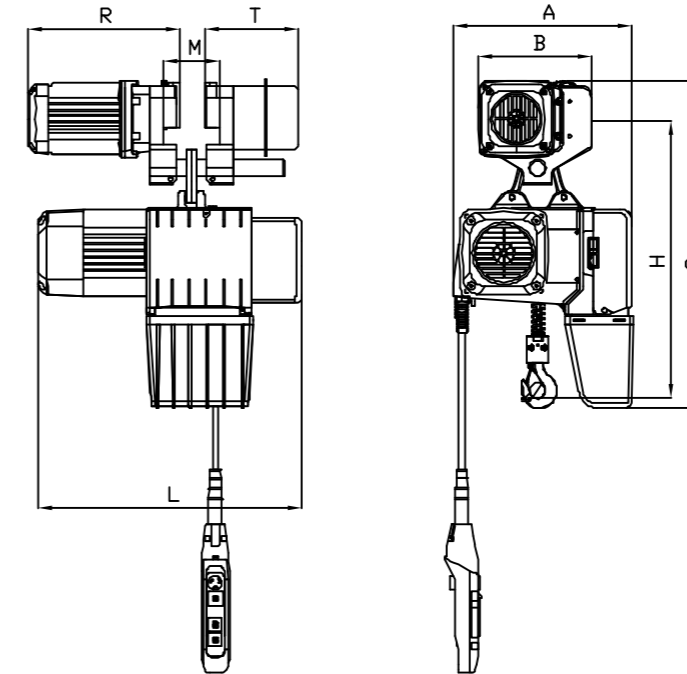

Specifications 规格

Capacity 额定载荷 (t)	Product Code 型号	Standard Lift Height 标准起升高度 (m)	Lifting Motor 起升电机		Travelling Motor 运行电机		Load Chain 载重链 Diameter x Falls 载重链直径 x 回数 (mm)	Voltage 电压 (v)	Test Load 实验载荷 (t)	Net Weight 净重	
			Lifting Speed 起升速度(m/min)	Output 输出功率 (kW)	Traversing Speed 运行速度(m/min)	Output 输出功率 (kW)				Hoist 葫芦 (kg)	Trolley 跑车 (kg)
			50Hz	60Hz	50Hz	60Hz	(kW)	(mm)	(t)	(kg)	(kg)
125kg	DMG0.125-01DM	3	8/2	9.6/2.6	0.37/0.1	20 (10)	24 (12)	0.4	3 (Phase)	156kg	28kg
	DMG0.125-01DF		13/3.2	16.3/3.8	0.75/0.2						
250kg	DMG0.25-01DM		8/2	9.6/2.6	0.4/0.12	Φ5.0 x 1	220-440 (V)	625kg	32kg		
500kg	DMG0.5-01DM		4/1	4.8/1.2	0.75/0.2					Φ5.0 x 2	50/60 (Hz)
1000kg	DMG01-02DM										

Dimensions (mm) 尺寸

Capacity 额定载荷 (t)	Product Code 型号	H	A	B	S	L	R	T
125kg	DMG0.125-01DM	445	315	201	470	440	260	164
	DMG0.125-01DF				495	464		
250kg	DMG0.25-01DM				470	440		
500kg	DMG0.5-01DM				470	440		
1000kg	DMG01-02DM	525			495	464		

0.5t-10t HHEXP SF

Single lifting speed with hook Suspension (单速挂钩式)

Explosion-Proof Exectric Chain Hoist 防爆环链电动葫芦

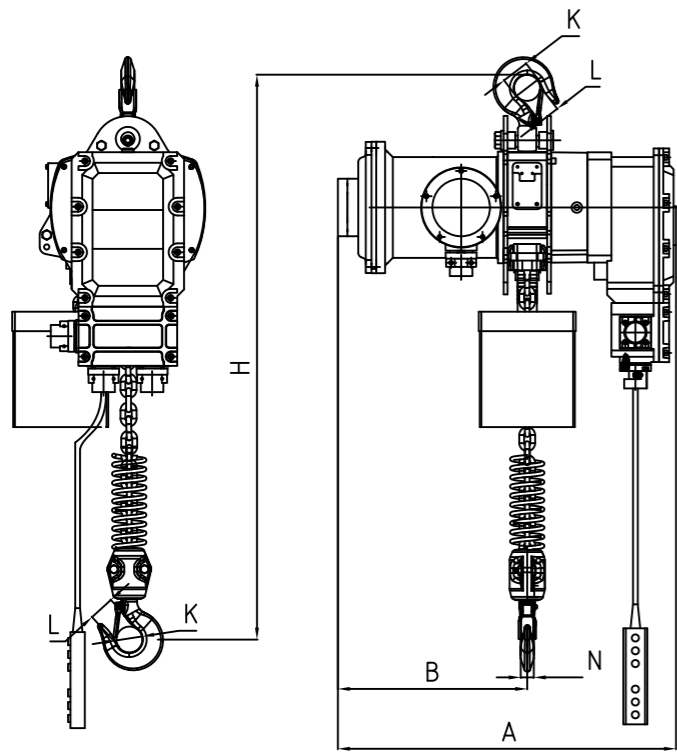

Specifications 规格

Capacity 额定载荷 (t)	Product Code 型号	Standard Lift Height 标准 起升高度 (m)	Lifting Motor 起升电机			Load Chain 载重链 Diameter x Falls 载重链直径 x 回数 (mm)	Voltage 电压 (v)	Test Load 实验载荷 (t)	Net Weight 净重 (kg)
			Lifting Speed 起升速度(m/min)		Output 输出功率 (kW)				
			50Hz	60Hz					
1000kg	HHEXP01-01SS	3	6.8	8.2	1.5	3 (Phase)	220-440 (V)	1250kg	/
2000kg	HHEXP02-01SS		3.4	4.1	3.0				
	HHEXP02-02SS		3.4	4.1	1.5				
3000kg	HHEXP03-01SS		5.4	6.5	3.0	20 (10)	24 (12)	3750kg	/
	HHEXP03-02SS		3.4	4.1	3.0				
	HHEXP03-03SS		1.8	2.2	1.5				
5000kg	HHEXP05-02SS		2.7	3.2	3.0	50/60 (Hz)	6250kg	/	/
7500kg	HHEXP7.5-03SS		1.8	2.2	3.0				
10000kg	HHEXP10-04SS		0.7	0.8	3.0 x 2				

Dimensions (mm) 尺寸

Capacity 额定载荷 (t)	Product Code 型号	H	A	D	E	K	B	L	N
1000kg	HHEXP01-01SS	650	600	300	176	Φ40	330	31	24
2000kg	HHEXP02-01SS	770	725	430	265	Φ49	350	35	30
	HHEXP02-02SS	740	600	300	230				
3000kg	HHEXP03-01SS	840	725	470	265	Φ59	330	42	35
	HHEXP03-02SS	920		430	320				
	HHEXP03-03SS	600	350	280					
5000kg	HHEXP05-02SS	1015	725	430	325	Φ60	350	45	43
7500kg	HHEXP7.5-03SS	1200	725	500	380	Φ90	350	70	50
10000kg	HHEXP10-04SS			890	445				

0.5t-10t HHEXP SF

Single lifting speed with with Motorized trolley (单速带电动小车式)

Explosion-Proof Exectric Chain Hoist 防爆环链电动葫芦

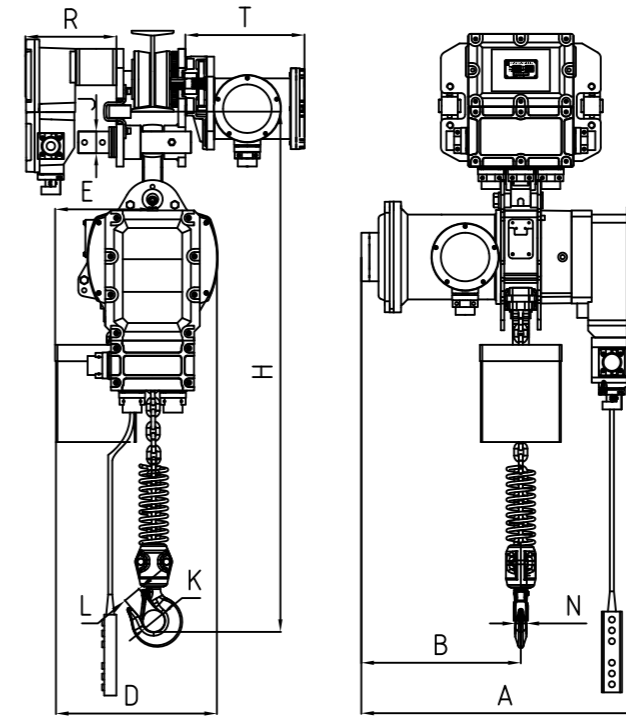

Specifications 规格

Capacity 额定载荷 (t)	Product Code 型号	Standard Lift Height 标准 起升高度 (m)	Lifting Motor 起升电机			Travelling Motor 运行电机		Load Chain 载重链 Diameter x Falls 载重链直径 x 回数 (mm)	Flange Width 工字钢 (mm)	Voltage 电压 (v)	Test Load 实验载荷 (t)	Net Weight 净重 (kg)
			Lifting Speed 起升速度(m/min)		Output 输出功率 (kW)	Traversing Speed 运行速度(m/min)	Output 输出功率 (kW)					
			50Hz	60Hz								
1000kg	HHEXP01-01SM	3	6.8	8.2	1.5	20 (10)	24 (12)	0.4	80-160	3 (Phase)	2500kg	/
2000kg	HHEXP02-01SM		3.4	4.1	3.0							
	HHEXP02-02SM		3.4	4.1	1.5							
3000kg	HHEXP03-01SM		5.4	6.5	3.0	50/60 (Hz)	6250kg	/				
	HHEXP03-02SM		3.4	4.1	3.0							
	HHEXP03-03SM		1.8	2.2	1.5							
5000kg	HHEXP05-02SM		2.7	3.2	3.0	0.75	6250kg	/				
7500kg	HHEXP7.5-03SM		1.8	2.2	3.0							
10000kg	HHEXP10-04SM		0.7	0.8	3.0 x 2				12500kg			

Dimensions (mm) 尺寸

Capacity 额定载荷 (t)	Product Code 型号	H	A	B	D	E	K	L	N	J	R	T	P	Q
1000kg	HHEXP01-01SM	650	600	330	300	176	Φ40	31	24	Φ31				
2000kg	HHEXP02-01SM	770	725	350	430	265	Φ49	35	30	Φ36				
	HHEXP02-02SM	740	600		300	230								
3000kg	HHEXP03-01SM	840	725	330	470	265	Φ59	42	35	Φ43	224	298	/	/
	HHEXP03-02SM	920			430	320								
	HHEXP03-03SM	600	350		280									
5000kg	HHEXP05-02SM	1015	725	350	430	325	Φ60	45	43	Φ54				
7500kg	HHEXP7.5-03SM	1200	725	350	500	380	Φ90	70	50	Φ70				
10000kg	HHEXP10-04SM				890	445				Φ54				

电动小车 Motorized Trolley

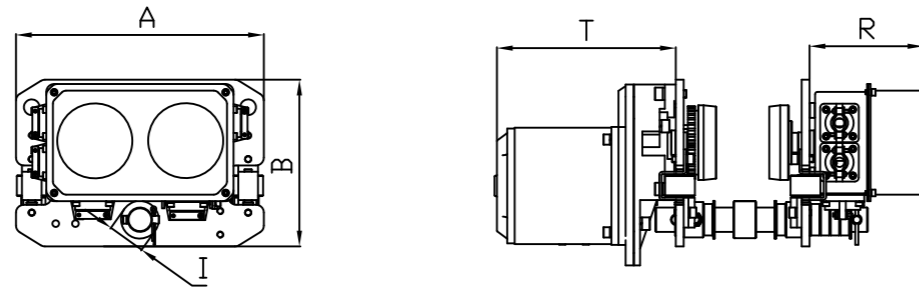

Dimensions (mm) 尺寸

Product Code型号	MT-0.5	MT-01	MT-02	MT-03	MT-05	MT-7.5	MT-10	
Capacity 载荷	500kg	1000kg	2000kg	3000kg	5000kg	7500kg	10000kg	
Unit 单位 (mm)	A	315	325	340	400	500		
	B	212	220	250	291	370		
	R	142						
	T	231						
	I	Φ31	Φ36	Φ43	Φ54	Φ70		
Traversing Speed 运行速度(m/min)	50hz	10(20)				10	10	
	60hz	12(24)				12	12	
Flange Width (mm) 工字钢	70-130	80-160	82-178	100-180	120-180	150-220		
Unit Weight (kg) 净重	22	41	49	61	82	138		
Min. Radius Curve 最小转弯半径(mm)	800		1000	1800	2500			

手动小车 Plain Trolley

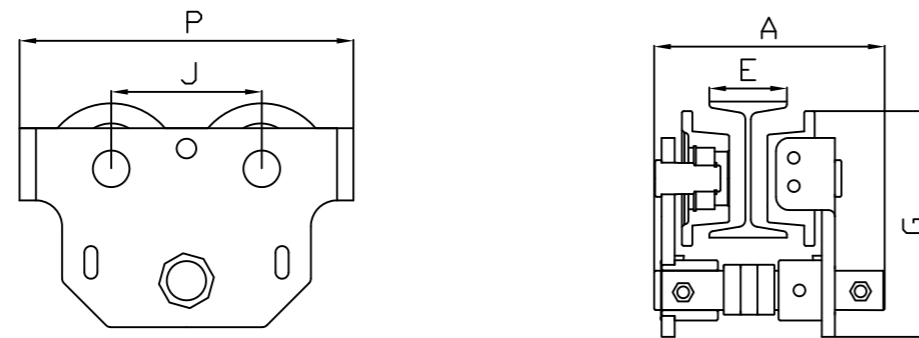

Dimensions (mm) 尺寸

Product Code型号	PT-0.5	PT-01	PT-02	PT-03	PT-05
Capacity 载荷	500kg	1000kg	2000kg	3000kg	5000kg
Unit 单位 (mm)	A	200	218	275	
	G	170	205	236	280
	J	115	138	157	178
	E	50-102	68-130	82-153	
	P	221	265	305	332
Unit Weight (kg) 净重	5.5	9.5	14.5	24.5	37.8
Min. Radius Curve 最小转弯半径(mm)	600		1000	1200	

Hoist Classifications

ISO/JIS

State of loading	Total duration of use (h)							
	200	400	800	1600	3200	6300	12500	25000
Light Mechanisms subjected very rarely to the maximum load and, normally, to light loads	-	-	M1	M2	M3	M4	M5	M6
Moderate Mechanisms subjected fairly frequently to the maximum load but, normally, to rather moderate loads	-	M1	M2	M3	M4	M5	M6	-
Heavy Mechanisms subjected frequently to the maximum load and, normally, to loads of heavy magnitude	M1	M2	M3	M4	M5	M6	-	-
Very heavy Mechanisms subjected regularly to the maximum load	M2	M3	M4	M5	M6	-	-	-

This classification refers to ISO 4301-1 and applies to the mechanical components including gears and bearings except for consumable parts.

ASME HST

Hoist duty class	Typical areas of application	Operation time ratings at $K=0.65$			
		Uniformly distributed work periods		Infrequent work periods	
		Max. on time, min/ hr	Max. No. starts/ hr	Max. on time from cold start, min	Max. No. of starts
H2	Light machine shop fabricating, service, and maintenance; loads and utilization randomly distributed; rated loads infrequently handled	7.6 (12.5%)	75	15	100
H3	General machine shop fabricating, assembly, storage, and warehousing; loads and utilization randomly distributed	15 (25%)	150	30	200
H4	High volume handling in steel warehouses, machine shops, fabricating plants and mills, and foundries; manual or automatic cycling operations in heat treating and plating; loads at or near rated load frequently handled	30 (50%)	300	30	300

The grade symbols are identical to those of ASME HST-1M. (Performance standard for Electric Chain Hoist)

FEM Relation between ISO-and FEM-Denominations

1 D _m	1 C _m	1 B _m	1 A _m	2 m	3 m	4 m	5 m
M 1	M 2	M 3	M 4	M 5	M 6	M 7	M 8

Load spectrum	Cubic mean value	Class of operation time									
		V 0.06	V 0.02	V 0.25	V 0.5	V 1	V 2	V 3	V 4	V 5	
		T 0	T 1	T 2	T 3	T 4	T 5	T 6	T 7	T 8	
Average operating time per day in hours											
≤0.12	≤0.25	≤0.5	≤1	≤2	≤4	≤8	≤16	>16			
1 L1	$K \leq 0.50$	-	-	1 D _m	1 C _m	1 B _m	1 A _m	2 m	3 m	4 m	
2 L2	$0.50 < K \leq 0.63$	-	1 D _m	1 C _m	1 B _m	1 A _m	2 m	3 m	4 m	5 m	
3 L3	$0.63 < K \leq 0.80$	1 D _m	1 C _m	1 B _m	1 A _m	2 m	3 m	4 m	5 m	-	
4 L4	$0.80 < K \leq 1.00$	1 C _m	1 B _m	1 A _m	2 m	3 m	4 m	5 m	-	-	

Class of operating time	Average operating time per day (in hours)	Calculated total operating time (in hours)	
V0.06	T0	≤0.12	200
V0.12	T1	≤0.25	400
V0.25	T2	≤0.5	800
V0.5	T3	≤1	1,600
V1	T4	≤2	3,200
V2	T5	≤4	6,300
V3	T6	≤8	12,500
V4	T7	≤16	25,000
V5	T8	>16	50,000

The grade symbols are identical to those of FEM 9.511. (Rules for Design of Serial Lifting Equipment: Classification of Mechanisms)